

## Produktbeschreibung

Putian kleiner und mittlerer Vibrationsmotor, 300/3400/3200/15300/15, professionelle Vibrationsmotorfabrik, Qualitätssicherung

Putian small and medium-sized vibration motor, 300 / 3400 / 3200 / 15300 / 15, professional vibration motor factory, quality assurance

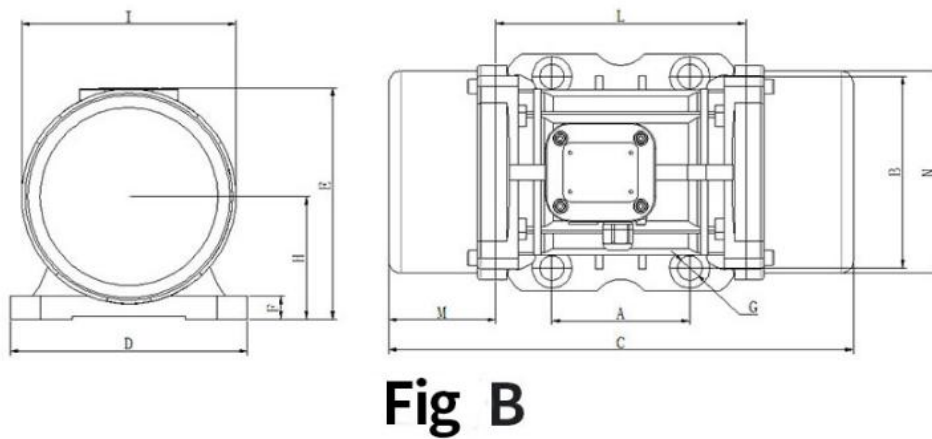
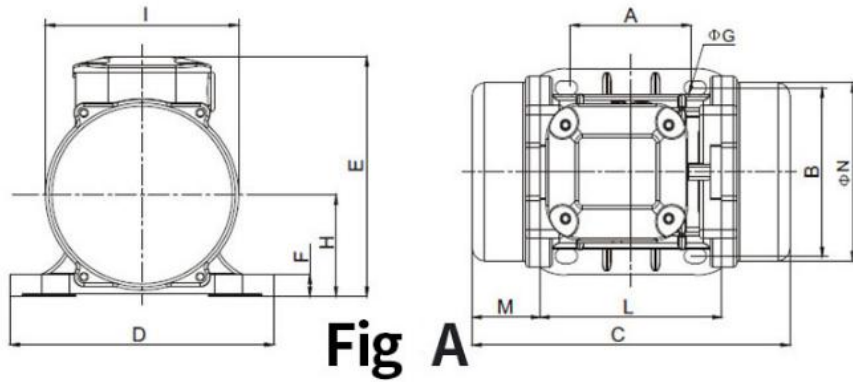

### 3相2极 3Phae2pole

型号 Type	额定力 Flrce		转速 Speed rpm	滑差功率 Power kw	电流 Current A	安装外形尺寸(毫米) Installation dimensions														电线接头 Cable Gland	重量 Weight kg	机座号 Size	图号 Fig
	kg	kN				A	B	C	D	E	F	φG	H	I	L	M	N						
MVE60/3	71	0.7	3000	0.03	0.16	62-74	106	211	130	136	12	9	48	94	121	45	86	M16*1.5	4.2	SIZE10	A		
MVE100/3	99	1	3000	0.04	0.19	62-74	106	221	130	136	12	9	48	94	121	50	86	M16*1.5	4.6	SIZE10	A		
MVE200/3	198	2	3000	0.09	0.35	62-74	106	231	131	159	15	9	64	121	123	54	112	M20*1.5	6.8	SIZE20	A		
MVE300/3	311	3	3000	0.16	0.52	90	125	253	155	175	15	13	79	142	163	45	131	M20*1.5	9.8	SIZE30	B		
MVE400/3	400	4	3000	0.2	0.58	90	125	273	155	175	15	13	79	142	163	55	131	M20*1.5	10.3	SIZE30	B		
MVE500/3	516	5	3000	0.37	0.96	105	140	334	168	196	22	13	92	169	178	78	158	M20*1.5	15.8	SIZE40	B		
MVE700/3	750	7	3000	0.45	1.25	105	140	334	168	196	22	13	92	169	178	78	158	M20*1.5	16.5	SIZE40	B		
MVE800/3	788	8	3000	0.55	1.45	120	170	321	208	210	22	17	94	180	205	58	170	M20*1.5	20.6	SIZE50	B		
MVE1200/3	1018	10	3000	0.75	1.85	120	170	321	208	210	22	17	94	180	205	58	170	M20*1.5	21.6	SIZE50	B		
MVE1300/3	1386	13	3000	1.1	2.44	120	170	321	208	210	22	17	94	180	205	58	170	M20*1.5	24.5	SIZE50	B		
MVE1600/3	1571	16	3000	1.25	2.94	140	190	416	229	262	30	17	120	247	220	80	222	M25*1.5	51.6	SIZE60	B		
MVE1800/3	1848	18	3000	1.5	3.75	140	190	416	229	262	30	17	120	247	220	80	222	M25*1.5	52	SIZE60	B		
MVE2000/3	2033	20	3000	2	4.07	140	190	416	229	262	30	17	120	247	220	80	222	M25*1.5	51.8	SIZE60	B		
MVE2200/3	2206	22	3000	2	4.07	140	190	416	229	262	30	17	120	247	220	80	222	M25*1.5	52.8	SIZE60	B		
MVE2300/3	2310	23	3000	2	4.44	140	190	416	229	262	30	17	120	247	220	80	222	M25*1.5	53.6	SIZE60	B		
MVE3200/3	3250	32	3000	2.2	5.3	155	255	538	302	318	35	25	147	295	273	115	264	M32*1.5	96.9	SIZE75	B		
MVE4000/3	4030	40	3000	2.3	5.3	155	255	538	302	318	35	25	147	295	273	115	264	M32*1.5	107	SIZE75	B		
MVE5000/3	5070	50	3000	3.5	7.22	155	255	588	302	318	35	25	147	295	273	140	264	M32*1.5	112	SIZE75	B		
MVE6500/3	6500	65	3000	4.2	8.2	200	320	605	378	411	49	28	200	421	325	120	378	M32*1.5	228.4	SIZE85	B		
MVE9000/3	9030	90	3000	7.2	17.8	200	320	605	378	411	49	28	200	421	325	120	378	M32*1.5	240.3	SIZE85	B		

### 3相4极 3Phae4pole

型号 Type	额定力 Flrce		转速 Speed rpm	滑差功率 Power kw	电流 Current A	安装外形尺寸(毫米) Installation dimensions														电线接头 Cable Gland	重量 Weight kg	机座号 Size	图号 Fig
	kg	kN				A	B	C	D	E	F	φG	H	I	L	M	N						
MVE40/15	32	0.3	1500	0.03	0.26	62-74	106	221	130	136	12	9	48	94	121	50	86	M16*1.5	4.6	SIZE10	A		
MVE90/15	90	0.9	1500	0.04	0.31	62-74	106	231	131	159	15	9	64	121	123	54	112	M20*1.5	7.4	SIZE20	A		
MVE200/15	183	2	1500	0.06	0.49	90	125	273	154	175	15	13	79	142	163	70	131	M20*1.5	11.8	SIZE30	B		
MVE250/15	257	2.5	1500	0.07	0.54	90	125	303	154	175	15	13	79	142	163	70	131	M20*1.5	13.2	SIZE30	B		
MVE300/15	305	3	1500	0.08	0.62	90	125	303	156	175	15	13	79	142	163	70	131	M20*1.5	16.5	SIZE30	B		
MVE400/15	388	4	1500	0.15	0.84	105	140	334	168	196	22	13	92	169	178	78	158	M20*1.5	19.5	SIZE40	B		
MVE500/15	518	5	1500	0.25	1.06	105	140	334	168	196	22	13	92	169	178	78	158	M20*1.5	21	SIZE40	B		
MVE700/15	693	7	1500	0.37	1.32	120	170	391	208	210	22	17	94	180	205	93	170	M20*1.5	27.4	SIZE50	B		
MVE800/15	807	8	1500	0.4	1.36	120	170	391	208	210	22	17	94	180	205	93	170	M20*1.5	28.3	SIZE50	B		
MVE1100/15	1045	11	1500	0.4	1.4	120	170	451	208	210	22	17	94	180	205	123	170	M20*1.5	35.8	SIZE50	B		
MVE1400/15	1406	14	1500	0.45	1.78	140	190	448	229	262	30	17	120	247	220	96	222	M25*1.5	59.8	SIZE60	B		
MVE1700/15	1757	17	1500	0.75	2.09	140	190	448	229	262	30	17	120	247	220	96	222	M25*1.5	61.8	SIZE60	B		
MVE2400/15	2420	24	1500	1	3.2	140	190	514	229	262	30	17	120	247	220	129	222	M25*1.5	68	SIZE60	B		
MVE2500/15	2500	25	1500	1.2	3.4	155	225	522	272	295	40	22	141	267	250	123	235	M25*1.5	90	SIZE70	B		
MVE3000/15	3065	30	1500	1.5	3.68	155	225	522	272	295	40	22	141	267	250	123	235	M25*1.5	97.5	SIZE70	B		
MVE3800/15	3830	38	1500	1.72	4.15	155	225	588	302	318	35	23.5	147	295	273	140	264	M32*1.5	130.4	SIZE75	B		
MVE4300/15	4312	43	1500	1.94	4.5	155	225	588	302	318	35	23.5	147	295	273	140	264	M32*1.5	134.4	SIZE75	B		
MVE5500/15	5576	55	1500	2.2	6.5	180	280	603	332	360	37	26	168	345	304	130	310	M32*1.5	192.2	SIZE80	B		
MVE7200/15	7188	72	1500	3	9.6	200	320	608	378	411	49	28	200	424	325	120	378	M32*1.5	253	SIZE85	B		
MVE9000/15	8984	90	1500	5.8	13.4	200	320	608	378	411	49	28	200	424	325	120	378	M32*1.5	268.6	SIZE85	B		

### 3相6极 3Phae6pole

型号	推力		转速	推力功率	电流	安装外形尺寸(毫米) Installation dimensions														电线接头	重量	机座号	图号
	Type	Flrce kg				kN	Speed rpm	Power kw	Current A	A	B	C	D	E	F	φG	H	I	L				
MVE50/1	51	0.5	1000	0.03	0.38	90	125	273	154	175	15	13	79	142	163	55	131	M20*1.5	10.4	SIZE30	B		
MVE100/1	105	1	1000	0.04	0.42	90	125	303	154	175	15	13	79	142	163	70	131	M20*1.5	12.2	SIZE30	B		
MVE200/1	185	1.8	1000	0.05	0.48	105	140	334	168	196	22	13	92	169	178	78	158	M20*1.5	19.6	SIZE40	B		
MVE300/1	308	3	1000	0.16	0.67	120	170	391	208	210	22	17	94	180	205	93	170	M20*1.5	26.6	SIZE50	B		
MVE400/1	408	4	1000	0.25	0.78	120	170	451	208	210	22	17	94	180	205	123	170	M20*1.5	30.5	SIZE50	B		
MVE500/1	510	5	1000	0.37	1.22	120	170	451	208	210	22	17	94	180	205	123	170	M20*1.5	34	SIZE50	B		
MVE800/1	781	7.8	1000	0.45	1.26	140	190	448	229	262	30	17	120	247	220	96	222	M25*1.5	61.8	SIZE60	B		
MVE1100/1	1067	11	1000	0.55	1.42	140	190	514	229	262	30	17	120	247	220	129	222	M25*1.5	79.4	SIZE60	B		
MVE1400/1	1378	14	1000	0.7	1.95	140	190	562	229	262	30	17	120	247	220	154	222	M25*1.5	81.7	SIZE60	B		
MVE1500/1	1500	15	1000	0.7	2	140	190	562	229	262	30	17	120	247	220	154	222	M25*1.5	83.6	SIZE60	B		
MVE1600/1	1600	16	1000	0.75	2.06	140	190	562	229	262	30	17	120	247	220	154	222	M25*1.5	85.4	SIZE60	B		
MVE1620/1	1622	16	1000	0.75	2.06	155	225	556	272	295	40	22	141	267	250	140	235	M25*1.5	99.8	SIZE70	B		
MVE2100/1	2026	21	1000	1.1	2.88	155	225	590	272	295	40	22	141	267	250	170	235	M25*1.5	114.3	SIZE70	B		
MVE2600/1	2573	26	1000	1.5	3.63	155	255	708	302	318	35	23.5	147	295	273	200	264	M32*1.5	148.6	SIZE75	B		
MVE3000/1	2931	30	1000	1.7	4.17	155	255	708	302	318	350	23.5	147	295	273	200	264	M32*1.5	155.4	SIZE75	B		
MVE3800/1	3835	38	1000	2	4.67	180	280	683	332	360	37	26	168	345	304	170	310	M32*1.5	215.6	SIZE80	B		
MVE4700/1	4721	47	1000	2.35	6.01	180	280	733	332	360	37	26	168	345	304	195	310	M32*1.5	230.8	SIZE80	B		
MVE5200/1	5193	52	1000	2.6	6.92	200	320	688	378	411	49	28	200	424	325	160	378	M32*1.5	279.8	SIZE85	B		
MVE6500/1	6491	65	1000	2.9	7.76	200	320	688	378	411	49	28	200	424	325	160	378	M32*1.5	304.4	SIZE85	B		
MVE8000/1	8018	80	1000	4.5	12.6	200	320	788	378	411	49	28	200	424	325	210	378	M32*1.5	325.2	SIZE85	B		
MVE9000/1	8936	90	1000	5	13.2	200	320	788	378	411	49	28	200	424	325	210	378	M32*1.5	337.8	SIZE85	B		

### 3相8极 3Phae8pole

型号	推力		转速	推力功率	电流	安装外形尺寸(毫米) Installation dimensions														电线接头	重量	机座号	图号
	Type	Flrce kg				kN	Speed rpm	Power kw	Current A	A	B	C	D	E	F	φG	H	I	L				
MVE150/075	105	1	750	0.08	0.38	105	140	334	168	196	22	13	92	169	178	78	158	M20*1.5	21.4	SIZE40	B		
MVE250/075	180	2	750	0.12	0.67	120	170	390	208	210	22	17	94	180	205	93	170	M20*1.5	29.5	SIZE50	B		
MVE400/075	264	2.5	750	0.12	0.73	120	170	451	208	210	22	17	94	160	205	123	170	M20*1.5	35	SIZE50	B		
MVE650/075	431	4.5	750	0.2	0.96	140	190	448	229	262	30	17	120	247	220	96	222	M25*1.5	64.7	SIZE60	B		
MVE900/075	589	6	750	0.45	1.29	140	190	514	229	262	30	17	120	247	220	129	222	M25*1.5	71	SIZE60	B		
MVE1300/075	941	9	750	0.56	1.86	155	225	556	272	295	40	22	141	267	250	140	235	M25*1.5	99.8	SIZE70	B		
MVE2100/075	1468	15	750	1	2.81	155	255	708	302	318	35	23.5	147	295	273	200	264	M32*1.5	150.4	SIZE75	B		
MVE3100/075	2137	21	750	1.4	3.79	180	280	683	332	360	37	26	168	345	304	170	310	M32*1.5	212.2	SIZE80	B		
MVE3800/075	2633	25	750	1.75	4.5	180	280	733	332	360	37	26	168	345	304	195	310	M32*1.5	230.2	SIZE80	B		
MVE4200/075	2920	30	750	2.1	5.26	200	320	688	378	410	49	28	200	422	325	160	378	M32*1.5	284.5	SIZE85	B		
MVE5300/075	3660	35	750	2.7	7.26	200	320	688	378	410	49	28	200	422	325	160	378	M32*1.5	305	SIZE85	B		
MVE6500/075	4510	45	750	3.65	9.93	200	320	788	378	410	49	28	200	422	325	210	378	M32*1.5	324.2	SIZE85	B		







# SEIKO MANUFACTURING



**Stator**

F-Pole Insulation Grade  
High temperature resistance



**Eccentric block**

Adjusting exciting force  
Satisfy all kinds of work needs



**Power Wire Sheath**

Anti-oxidation and anti-distortion



**Bearing**

Precision, Low Noise and Wear Resistance

# How to choose the right motor?

1. (Old Users) Check parameters or take pictures of old motor nameplates



2. (New user) Calculate the total weight of material and equipment on the upper part of spring, industry, use environment, etc.





# SERVE ALL WALKS OF LIFE

Screening, grading, cutting, anti-blocking, and other vibration sources

